

# Magnetic Door Position Switch

## 126 GuardSwitch

### Applications

- Closet Door Switch
- Environmental Controls

### General Specifications

Enclosure	ABS Plastic with Protective Nylon
Switch Sleeve	
Temperature Range	-40°F to 180°F (-40°C to 80°C)
NEMA Rating	1, 2, 3, 4, 4x, 5, 6, 12
Protection Class	IP 67
Response Time	10 msec
Life Cycles	100,000 Under Full Load; Up to 200,000,000 Under Dry Circuit
Lead Types/O.D.	12 AWG (AX) / 0.13" (0.33cm) Flex Conduit (X) / 0.58" (1.5cm)
UL/CSA	All Models

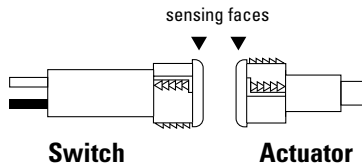
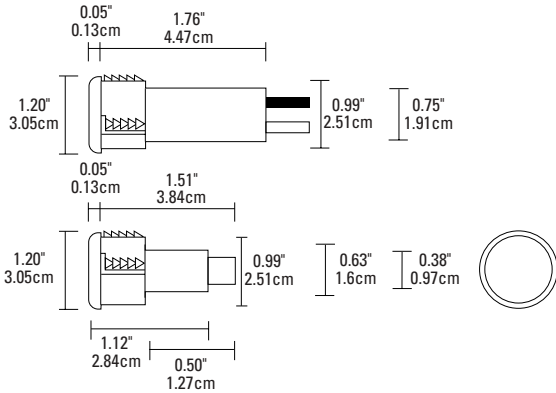

New York  
Calendar # 40018

INTERLOCK SWITCH  
100 SERIES

Order Information	Electrical Specifications				AC ONLY			
Part Number	Contact <sup>1</sup> Config.	Load Rating (AC)	Switching Voltage Maximum (AC)	Switching Current <sup>3</sup> Maximum (AC)	Voltage Drop	Sense Range <sup>2</sup> Nominal	Break Range Nominal	Lead Length
126-EY-01AX	N.C.	150VA	120V AC	1.25A	1.5V	1.0" (2.5cm)	1.5" (3.8cm)	1' (0.3m)
126-EY-06X	N.C.	150VA	120V AC	1.25A	1.5V	1.0" (2.5cm)	1.5" (3.8cm)	6' (1.8m)
126-8Y-01AX	N.O.	150VA	120V AC	1.25A	1.5V	1.0" (2.5cm)	1.5" (3.8cm)	1' (0.3m)
126-EY-03AX	N.C.	150VA	120V AC	1.25A	1.5V	1.0" (2.5cm)	1.5" (3.8cm)	3' (0.9m)
126-Y	Actuator Only							

**Warning— Each electrical rating is an individual maximum and cannot be exceeded!**

- <sup>1</sup> Configuration with actuator away from the switch
- <sup>2</sup> Proximity of ferrous materials usually reduces sense range — typically by 50%. The shape and type of material cause a wide diversity of effects. Testing is required to determine actual sense range for specific applications.
- <sup>3</sup> Can withstand inrush surge up to 4 amps. Voltage Drop 1.5V, minimum switch current of 30mA.



**GE Interlogix  
Industrial**

www.GE-Interlogix.com/Industrial

## GuardSwitch™ Series 100 Magnetic Door Position Switch

- 126**
- |                                      |                                      |
|--------------------------------------|--------------------------------------|
| <input type="checkbox"/> 126-EY-01AX | <input type="checkbox"/> 126-8Y-03AX |
| <input type="checkbox"/> 126-EY-06X  | <input type="checkbox"/> 126-EY-03AX |
| <input type="checkbox"/> 126-8Y-01AX | <input type="checkbox"/> 126-_____   |
| <input type="checkbox"/> 126-8Y-06X  |                                      |

**Warning!** To avoid switch failure determine the actual load of the switch circuit and take steps to protect the switch from voltage spikes, current inrush and line/load capacitance using the following recommendations.

- Surges from coils, motors, contactors, solenoids and tungsten filaments. Transient protection, such as back-to-back zener diodes (Transorb) or an RC network, is recommended for such loads to ensure that maximum ratings of the switch are not exceeded.
- Line capacitance and load capacitance. An in-line resistor can be added in series immediately before the load to limit the inrush current. The resistor can only be added in series with the last wire just before the load. The voltage drop and the power rating of the resistor must also be calculated as follows:

$$\text{Voltage drop} = I \cdot R$$

$$\text{Watts} = I^2 \cdot R$$

( I = maximum continuous current of the load)

### To verify switch operation with an ohmmeter:

Set range at 20 mega ohms (switches with triac output, set ohm range at 20 kilo ohms). For a normally open switch, the meter will read a high impedance with the actuator away. It will read very high to infinity range (triac switches will read high kilo ohm to infinity range) with the actuator within sense range. You will see the opposite reading for a normally closed switch.

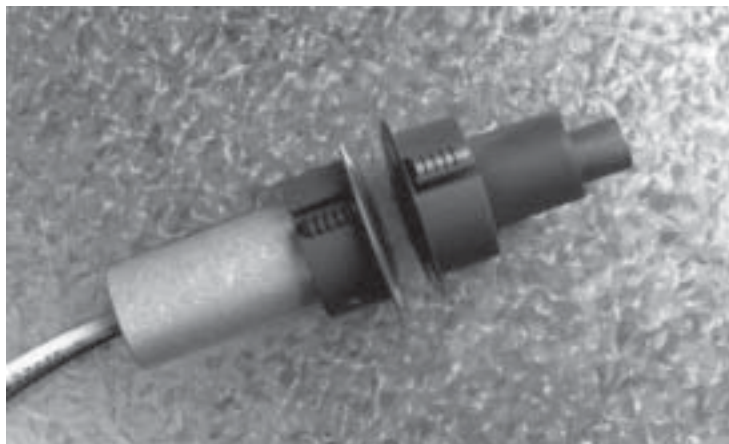

### Dimensions

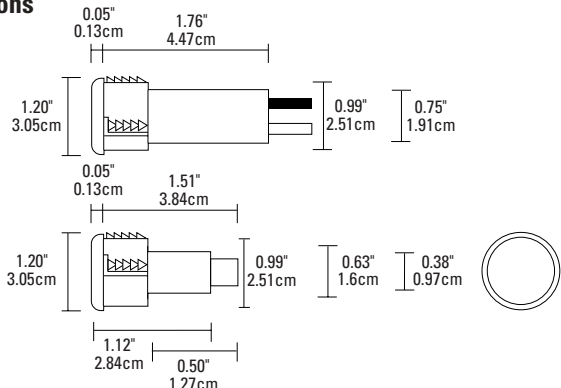

Figure 1

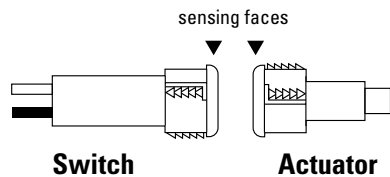
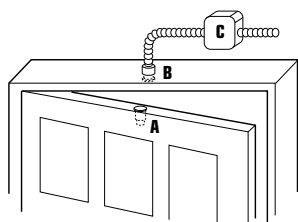

Figure 2



### Installation

The Model 126 is designed for use with tungsten filament bulbs of 150-watt rating or less at 120 volts.

1. Using the following guidelines, determine a suitable mounting location:
  - The switch and actuator must be within the listed sense range. See Ordering/Electrical Specifications.
  - The actuator must be aligned with the switch—labels facing the same direction. (See Figure 1.)
- Important:** When mounting in proximity to ferrous material (steel), the sense range can be reduced 50% minimum depending on the shape and type of material. Test the switch in specific applications to determine the actual sense range.
2. Determine location of switch on door jamb. To ensure proper operation and that the magnetic field not interfere with switching, do not locate closer than six inches from hinge side of door.
3. Locate switch (B) and magnet (A) locations on door jamb and door. (See Figure 2.) Drill a one-inch hole to accommodate these. (Do not hammer. This can damage the switch.) Misalignment of up to 1/2-inch can be tolerated, but not in a ferrous metal door. (To check if a door or jamb is ferrous hold a magnet to it. If it is attracted it is ferrous.)
4. Connect the black line conductor, see Figure 3, to the fuse and fuse holder that are provided. Connect the white neutral conductor to the load. Connect the flexible conduit to a NEMA Type I enclosure, see Figure 2.C, using a properly sized and acceptable 3/8 inch flexible conduit connector. If the switch is being used in a branch circuit, connect to a UL listed relay with minimum rating of 120VAC/15A.
5. The switch and actuator must move in one of the approved directions. See Figure 4.

**Note:** Before making electrical connections be sure that power is off. Electrical connections are black to line and white to load (bulb).

Figure 3

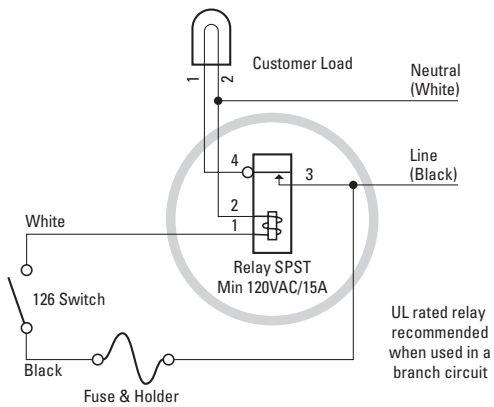
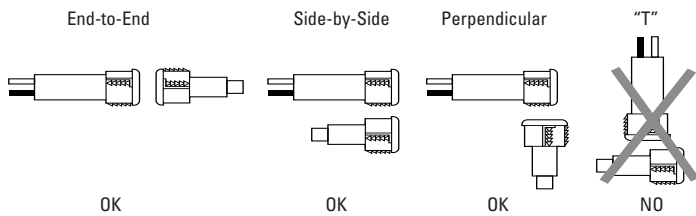

Figure 4  
Barrel Switch Mounting Configurations



Three configurations are appropriate for recessed interlock applications. Moving the actuator parallel to the switch can result in on/off/on signal if the actuator passes by the switch rather than coming to rest in proximity to it. This is NOT a recommended configuration for interlock/position applications. "T" configuration results in non-actuation.

### Ordering/Electrical Specifications

PART NUMBER	CONTACT <sup>1</sup> CONFIG.	LOAD RATING	SWITCHING VOLTAGE MAXIMUM	SWITCHING CURRENT MAXIMUM	SENSE RANGE <sup>2</sup> NOMINAL	BREAK RANGE NOMINAL	LEAD LENGTH NOMINAL
126-EY-01AX <sup>4</sup>	N.C./ triac output	150VA	120VAC	1.25A <sup>3</sup>	1.0"(2.5cm)	1.5"(3.8cm)	1'(0.3m)
126-EY-06X <sup>4</sup>	N.C./ triac output	150VA	120VAC	1.25A <sup>3</sup>	1.0"(2.5cm)	1.5"(3.8cm)	6'(1.8m)
126-8Y-01AX <sup>4</sup>	N.O./ triac output	150VA	120VAC	1.25A <sup>3</sup>	1.0"(2.5cm)	1.5"(3.8cm)	1'(0.3m)
126-8Y-06X <sup>4</sup>	N.O./ triac output	150VA	120VAC	1.25A <sup>3</sup>	1.0"(2.5cm)	1.5"(3.8cm)	6'(1.8m)
126-8Y-03AX <sup>4</sup>	N.O./ triac output	150VA	120VAC	1.25A <sup>3</sup>	1.0"(2.5cm)	1.5"(3.8cm)	3'(0.9m)
126-EY-03AX <sup>4</sup>	N.C./ triac output	150VA	120VAC	1.25A <sup>3</sup>	1.0"(2.5cm)	1.5"(3.8cm)	3'(0.9m)
126-Y	Actuator Only						

**Warning— Each electrical rating is an individual maximum and cannot be exceeded!**

- Configuration with actuator away from the switch
- Proximity of ferrous materials usually reduces sense range — typically by 50%. The shape and type of material cause a wide diversity of effects. Testing is required to determine actual sense range for specific applications.
- Can withstand inrush surge up to 4 Amps. Voltage Drop 1.5V. Minimum switch current 30mA.
- Maximum 25 switches in series.



**GE Interlogix  
Industrial**

www.GE-Interlogix.com/Industrial

12345 SW Leveton Drive  
Tualatin, OR 97062  
Phone: 800-247-9447  
Fax: 503-691-7563

### General Specifications

Enclosure	ABS Plastic with Protective PVC
	Switch Sleeve
Temperature Range	-40°F to 122°F (-40°C to 50°C)
NEMA Rating	1, 2, 3, 4, 4X, 5, 6, 12
Protection Class	IP 67
Response Time	10 msec
Life Cycles	100,000 Under Full Load; Up to 200,000,000 Under Dry Circuit
Lead Types/O.D.	12 AWG (AX)/0.13" (0.33cm) Flex Conduit (X)/0.58" (1.5cm)
UL/CSA Certified	All Models



New York Calendar #40018